

**SERIES 3 POST & PANEL:**

SERIES 3 - 3/4" RADIUS POST  
PART #1210

SERIES 2-3 REVEAL  
PART #1200

SERIES 3 - 3/4" SLIDE BODY  
PART #1260

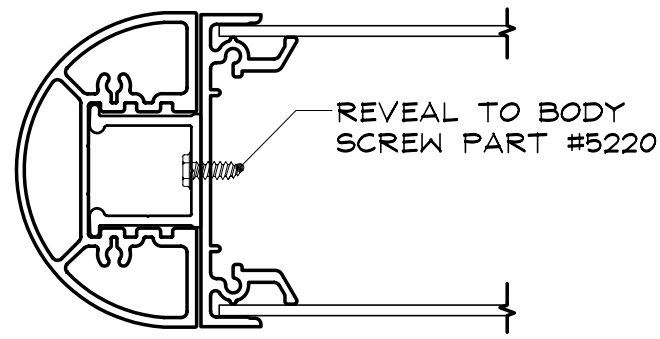

**0" REVEAL POSITION**

SCALE : 1/2" = 1"

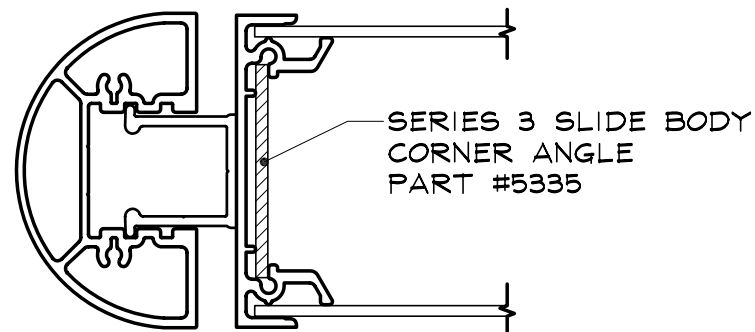

**3/8" REVEAL POSITION**

SCALE : 1/2" = 1"

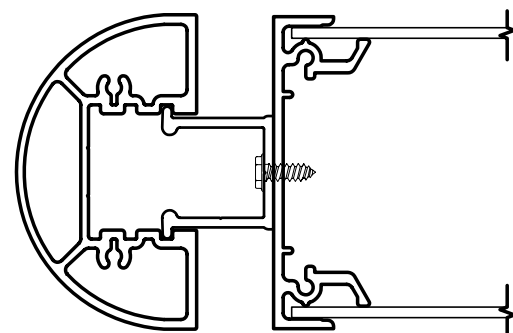

**3/4" REVEAL POSITION**

SCALE : 1/2" = 1"

FINISH GRADE  
OR  
TOP OF FOOTING

INSERT FILLER  
INTO POST TACK  
WELD IT UP TIGHT UP  
AGAINST SIGN BOTTOM  
LEAVING 6" OF FILLER  
BELOW GRADE.

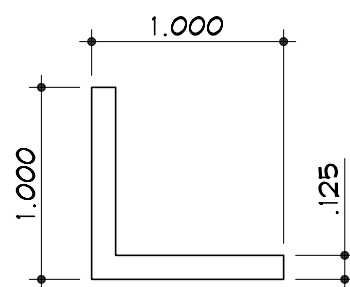
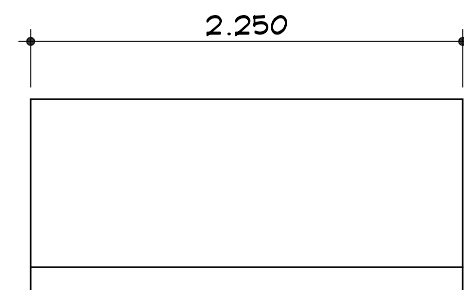

**CORNER ANGLE PART #5335**

SCALE : 1" = 1"

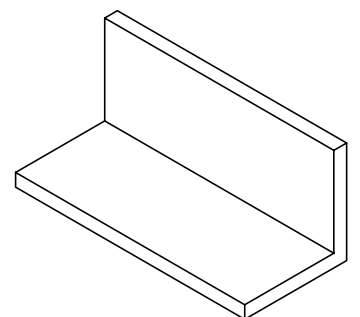
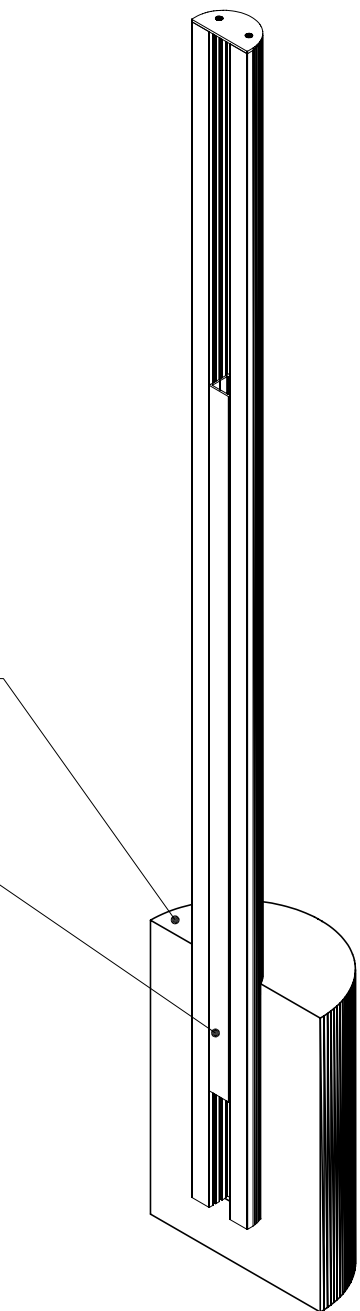

INSTALL REVEAL PIECE  
1/8" BELOW TOP OF SIGN  
TO ALLOW POST CAP  
TO ALIGN FLUSH WITH  
TOP OF SIGN.

SER 3 - 1210-1

